

KEY

- GATE VALVE
- BALL VALVE
- PRESSURE CONTROL VALVE
- FLOW METER
- SAFETY RELIEF VALVE
- BUTTERFLY VALVE
- NEEDLE VALVE
- FILTER

- PI - PRESSURE INDICATOR
- TI - TEMPERATURE INDICATOR
- PS - PRESSURE SWITCH
- PCV - PRESSURE CONTROL VALVE
- FI - FLOW INDICATOR

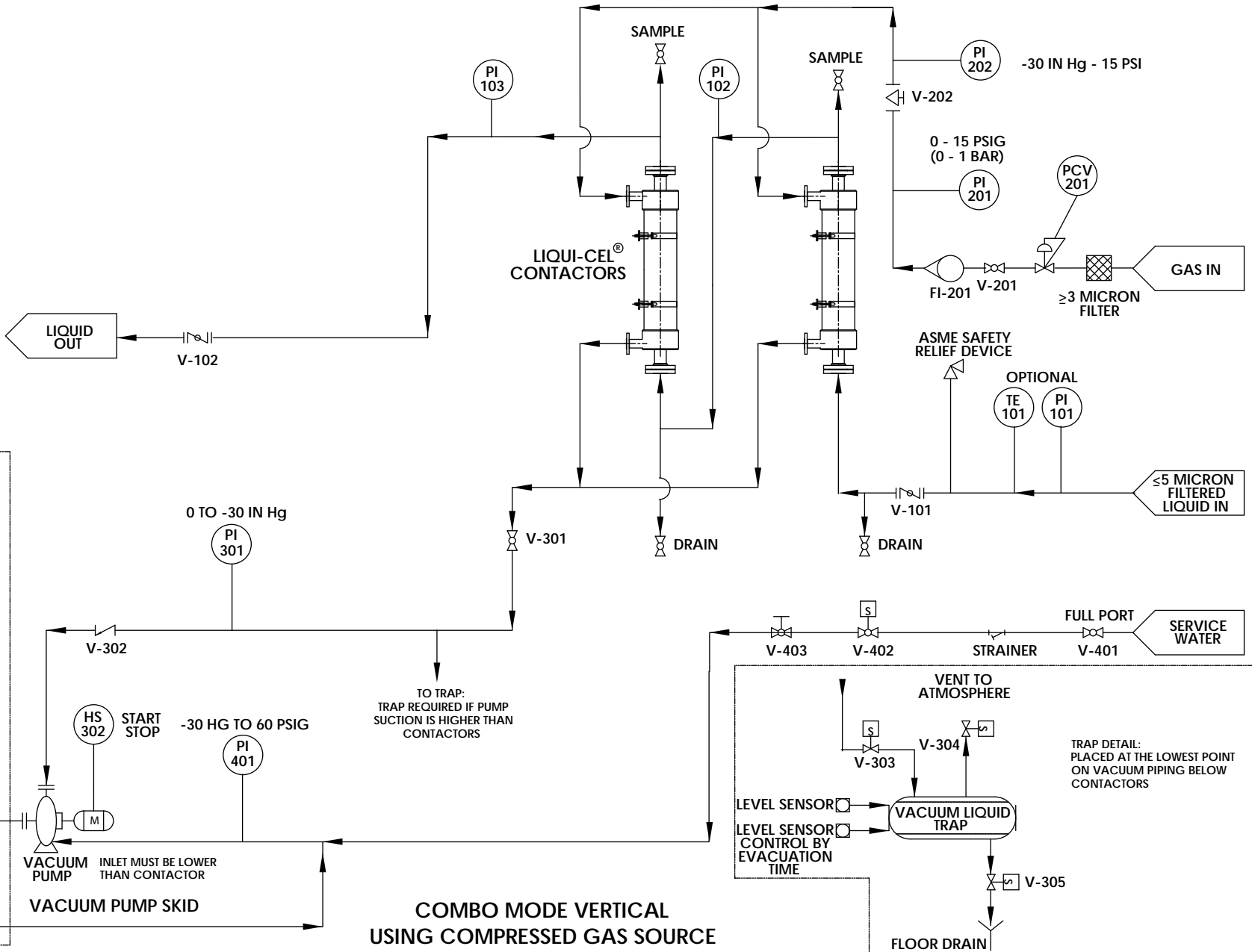

**COMBO MODE VERTICAL
USING COMPRESSED GAS SOURCE**

TRAP DETAIL:
PLACED AT THE LOWEST POINT
ON VACUUM PIPING BELOW
CONTACTORS